

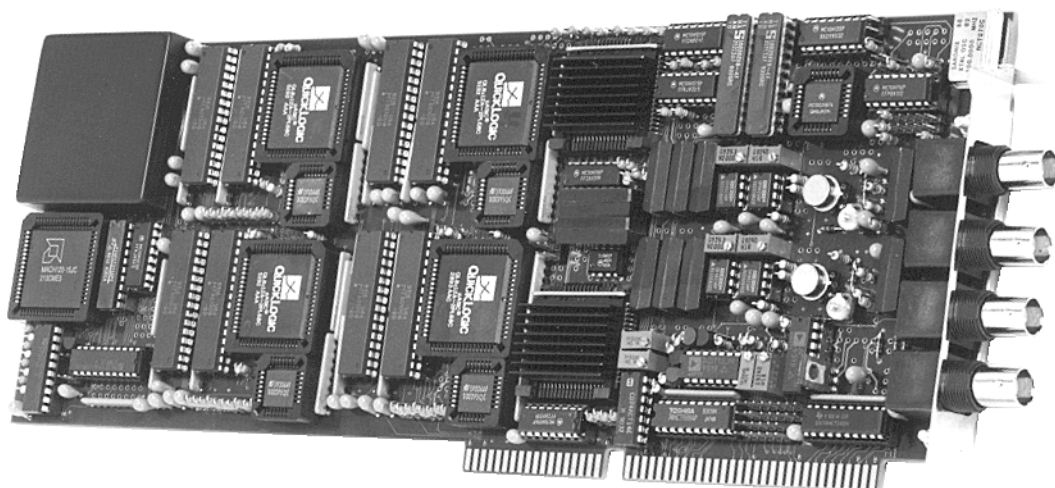

# SPECTRUM

SYSTEMENTWICKLUNG MICROELECTRONIC GMBH

## **PAD242 200 MHz / 400 MHz ISA transient recorder**



- **2 analoge Kanäle mit 8 Bit Auflösung**
  - **Simultane Aufnahme auf beiden Kanälen**
  - **200 MHz Abtastrate auf zwei Kanälen**
  - **400 MHz Abtastrate auf einem Kanal**
  - **Bis zu 4 MSamples Speicher**
  - **DSP-Link Interface zu Signalprozessoren**
- **2 analogue channels with 8 bit resolution**
  - **Simultaneously sampling on both channels**
  - **200 MHz samplerate on two channels**
  - **400 MHz samplerate on one channel**
  - **Up to 4 MSample memory**
  - **DSP-Link interface to signal processors**

### **Allgemeine Information**

Die PAD242 ist eine schnelle A/D-Wandler Karte für den ISA Bus. Zwei separate A/D-Wandler ermöglichen die simultane Aufnahme der beiden Kanäle ohne den bei Multiplexsystemen üblichen Zeitversatz.

Verschiedene Betriebsarten wie Speichersegmentierung, interner/externer Takt und Trigger sowie Pre- und Posttrigger erlauben eine flexible Anpassung des Meßsystems.

Der große on-board Speicher ermöglicht die Aufzeichnung extrem breitbandiger Signale.

**Anwendungsbeispiele: Spektroskopie, LDA/PDA, Ultraschall, Radar**

### **Software**

Kostenlos mitgeliefert werden Treiber für Linux, DOS und Windows 9x/ME/NT/2000/XP. Für die einfache Programmierung sind Beispiele in C/C++, Delphi und Visual Basic enthalten. Darüber hinaus steht zur komfortablen Steuerung die Signalverarbeitungssoftware SBench 5.2 kostenlos zur Verfügung. Außerdem sind Treiber für LabVIEW, DASyLab, MATLAB und VEE erhältlich.

### **General Information**

The PAD242 is a fast A/D-Converter board for ISA bus. Two separate A/D converters allow simultaneously sampling on both channels without the time offset produced by multiplex systems.

Several different operating modes like memory segmentation (multiple recording), internal and external clock and trigger enables a flexible adaption to the measurement problem.

The large on-board memory allows recording of signals with a wide bandwidth.

**Application examples: Spectroscopy, LDA/PDA, Supersonics, Radar**

### **Software**

Drivers for Linux, DOS and Windows 9x/ME/NT/2000/XP as well as programming examples for C/C++, Delphi and Visual Basic are delivered with the board. Comfortable programming, initialising and data display are performed by the free-of-charge Windows program SBench 5.2. Software drivers for LabVIEW, DASyLab, MATLAB and VEE are available.

## Software programmable parameters

Samplerate	781 kHz to 400 MHz, external clock
Input range	±200 mV, ±500 mV, ±1 V
Input Impedance	50 Ohm / 1 MOhm (jumper)
Input coupling	AC / DC (relais)
Memory depth	32 Samples up to installed memory in increments of 32 samples

Triggermode	channel 0, channel 1, external, software
Triggerlevel	1/16 ... 15/16 of the input range
Triggeredge	rising or falling edge
Posttrigger	64 Samples to 2 MSamples in increments of 64 samples

## Technical data

Resolution	8 bit
Samplerate	781 kHz up to 400 MHz
Bandwidth -3 dB	≥ 150 MHz
Differential linearity error	±0.5 LSB
Integral linearity error	±0.5 LSB
ENOB fs = 1 MHz, fck=200 MHz	6.4 bit typ. (ADC)
ENOB fs = 62 MHz, fck=200 MHz	5.2 bit typ. (ADC)
Aperture jitter	9 ps (ADC)
Input impedance	50 Ohm or 1 MOhm
Overvoltage protection	±20 V
Connector	9 mm BNC female

Multi: Trigger to 1 <sup>st</sup> sample delay	4 samples
Multi: Recovery time	8 samples
Trigger output delay	16 samples
Trigger accuracy (≤200 MHz)	4 samples
Trigger accuracy (400 MHz)	8 samples
Ext. clock: delay to internal clock	≤ 7 ns

Input range	±200 mV	±500 mV	±1 V
Offset error (200 MHz)	≤ 1 LSB	≤ 1 LSB	≤ 1 LSB
Offset error (400 MHz)	≤ 1 LSB	≤ 1 LSB	≤ 1 LSB
Gain error (200 MHz)	≤ 2.5 %	≤ 2.5 %	≤ 1 %
Gain error (400 MHz)	≤ 2.5 %	≤ 2.5 %	≤ 1 %
Noise (200 MHz)	≤ 2 LSB	≤ 2 LSB	≤ 1 LSB
Noise (400 MHz)	≤ 2 LSB	≤ 2 LSB	≤ 1 LSB
Crosstalk	-	-	-

Dimension	312 mm x 109 mm
Warm up time	10 minutes
Operating temperature	0°C - 50°C
Storage temperature	-10°C - 70°C
Humidity	10% to 90% non condensing

	-5 V	+5 V	+12 V	-12 V
Power consumption (A)	0 mA	3800 mA	0 mA	0 mA
Power consumption (W)	0.0 W	19.0 W	0.0 W	0.0 W

## Hardware block diagram

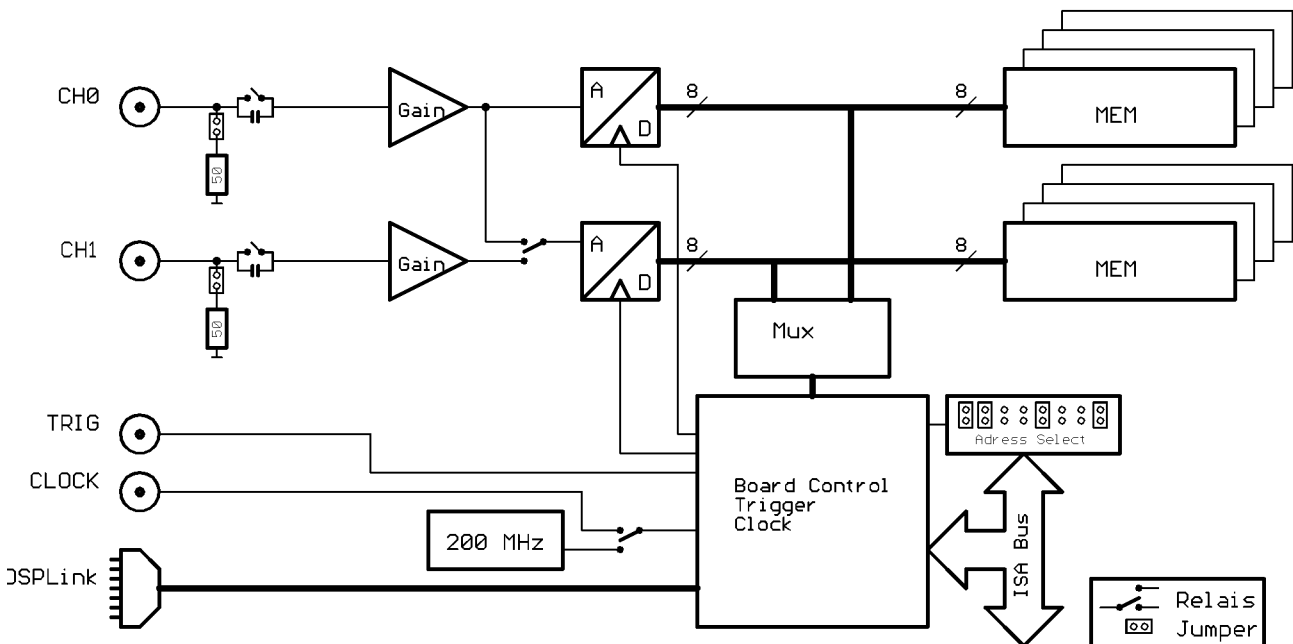

## Order information

PAD242 standard	PAD242 with 256 kSamples memory including drivers	PAD242
Option 1 M	Memory upgrading to 1 MSamples	PAD242-1
Option 4 M	Memory upgrading to 4 MSamples	PAD242-4
Multiple recording	Memory segmentation for fast repetition rates.	PAD242-mr
Input range	3 user specific input ranges between ±200 mV and ±3 V, bipolar or unipolar	PAD242-ir
DASYLab driver	Drivers for DASYLab 5.0 for Win 95/98, Win 2000 and Win NT	PAD242-dl
Agilent VEE driver	Drivers for Agilent VEE 5.0 for Win 95/98, Win 2000 and Win NT	PAD242-hp
LabVIEW driver	Drivers for LabVIEW 4.0 for Win 3.11, Win 95/98, Win 2000 and Win NT	PAD242-lv
MatLab driver	Drivers for MatLab 5.0 for Win 95/98, Win 2000 and Win NT	MATLAB

This board is an old product and is not recommended for new designs. Use PCI.248 instead.

Spectrum reserves the right to make changes at any time to improve design and to supply the best product possible