



# SPECTRUM

SYSTEMENTWICKLUNG MICROELECTRONIC GMBH

## PCI.DIO32 100 MHz 32 Bit Digital I/O

- High speed PCI interface
- Selectable 32 bit input or
- 32 bit output or
- 16 bit input and 16 bit output.
- 3.33 MHz to 100 MHz recording / replay
- Up to 32 MSamples (128 MB) memory
- Synchronisation with other Spectrum boards
- Clock and Trigger In-/Output



### Software/Drivers

A large number of drivers and examples are delivered with the board or are available as an option:

- Windows 98/ME/NT/2000/XP - drivers
- Linux - drivers
- SBench 5.3
- Microsoft Visual C++ examples
- Borland Delphi examples
- Microsoft Visual Basic examples
- Microsoft Excel examples
- LabWindows/CVI examples
- FlexPro support with SBench
- LabVIEW - drivers (as option)
- DASyLab - drivers (as option)
- MATLAB - drivers (as option)
- Agilent VEE - drivers (as option)

### General Information

The fast digital I/O board PCI.DIO32 works with two 16 bit channels. Each channel may be programmed individually as input or output. This results in a maximum of 32 bit for output or 32 bit for input. A system test mode with 16 bit input synchronously to 16 bit output is also implemented. For synchronisation purposes with external systems the board is equipped with a clock and trigger in/output. This allows the board to work with other boards from Spectrum as well as boards from other producers. An internal synchronisation bus allows to cascade multiple PCI.DIO32.

### Application examples

Semiconductor test      Production test  
Data acquisition      Logic analyser

### Hardware block diagram

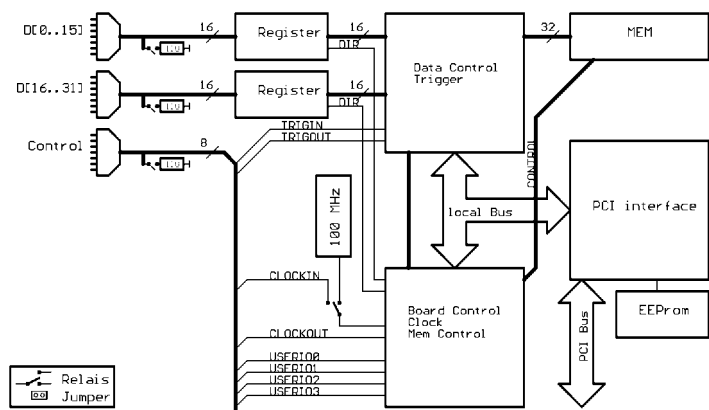

### Software programmable parameters

Sampling frequency:	3.33 MHz to 100 MHz, external clock
Direction:	32 bit input, 32 bit output, 16 bit input and 16 bit output
Input impedance:	110 Ohm / 50 kOhm for every 16 bit (relais)
Triggermode:	digital pattern and mask, external TTL (trigger in/out), software, single shot
Memory depth:	32 Samples up to installed memory in increments of 32 samples
Posttrigger:	32 Samples up to 32 MSamples in increments of 32samples

### Possibilities and options

#### Pattern trigger

For every bit of the digital input the pattern trigger defines individually the expected level or sets the bit to „don't care“. In combination with pulsewidth counter and edge detection the pattern trigger could be used to recognise a huge variety of trigger events.

#### External clock I/O

Using a dedicated connector a sampling clock can be fed in from an external system. It's also possible to output the internally used sampling clock to synchronise external equipment to this clock.

#### External trigger I/O

All boards can be triggered using an external TTL signal. It's possible to use positive or negative edge also in combination with a programmable pulse width. An

internally recognised trigger event can - when activated by software - be routed to the trigger connector to start external instruments.

### Cascading

The cascading option synchronises up to 4 Spectrum boards internally. It's the easiest way to build up a multi channel system. There is a phase delay between two boards of about 500 pico seconds when this synchronisation option is used.

### Singleshot output

When singleshot output is activated the data of the on-board memory is replayed exactly one time. As trigger source one can use the external TTL trigger or the software trigger.

### Continuous output

When continuous output is activated the data of the on-board memory is replayed continuously until a stop command is executed. As trigger source one can use the external TTL trigger or the software trigger.

### Multiple Recording

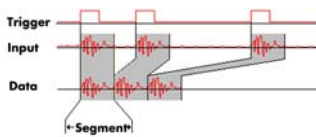

The Multiple Recording option allows the recording of several trigger events without restarting the hardware. With this option very fast repetition rates can be achieved. The on-board memory is divided in several segments of same size. Each of them is filled with data if a trigger event occurs.

### Multiple Replay

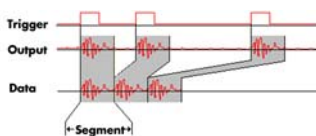

The Multiple Replay option allows the fast repetition output on several trigger events without restarting the hardware. With this option very fast repetition rates can be achieved. The on-board memory is divided in several segments of same size. Each of them is generated if a trigger event occurs.

### Gated Sampling

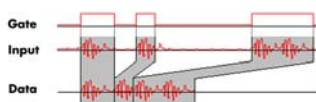

The Gated Sampling option allows data recording controlled by an external gate signal. Data is only recorded if the gate signal has a programmed level.

### Gated Replay

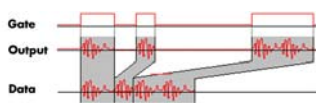

The Gated Sampling option allows data replay controlled by an external gate signal. Data is only replayed if the gate signal has a programmed level.

### Technical Data

Samplerate	3.33 MHz up to 100 MHz	Dimension	203 mm x 109 mm			
Input impedance	110 Ohm or 50 kOhm    15 pF	Connector	80 pin (2 * 40 pin flat ribbon cable 2.54 mm)			
Signal level	TTL	Operating temperature	0°C - 50°C			
Multi: Trigger to 1st sample delay	26 samples	Storage temperature	-10°C - 70°C			
Multi: Recovery time	21 samples	Humidity	10% to 90% non condensing			
Trigger output delay	5 samples	MTBF	300000 hours			
Trigger accurathy	1 sample					
Ext. clock: output delay	12.5 ns		+3.3 V	+5 V	+12 V	-12 V
Ext. clock: delay to internal clock	9.0 ns	Power consumption (A)	0 mA	2500 mA	0 mA	0 mA
Sync: board to board trigger jitter	0 samples	Power consumption (W)	0.0 W	12.5 W	0.0 W	0.0 W
Sync: board to board clock delay	1 ns					

### Order information

Order No	Description	Order No	Description
PCIDIO32	PCI.DIO32 with 8 MS (32 MBytes) memory including drivers & cable	PCIDIO32-mr	Option Multiple Recording/Replay: Memory segmentation
PCIDIO32-32	Option: 32 MSample memory instead of 8 MSample standard mem	PCIDIO32-gs	Option Gated Sampling: Gate signal controls acquisition/replay
PCIDIO32-up	Additional handling cost for later memory upgrade	PCIDIO32-dl	DASyLab driver for PCI.DIO32 series
PCIDIO32-ks	Synchronisation of 2 - 4 boards, one option per system	PCIDIO32-hp	VEE driver for PCI.DIO32 series
PCIDIO32-cab	Additional 80 pole flat ribbon cable to 2x40 pole IDC connector, ca. 1 m	PCIDIO32-lv	LabVIEW driver for PCI.DIO32 series
		MATLAB	MATLAB driver for all PCI boards.

Technical changes and printing errors possible