



SPECTRUM

SYSTEMENTWICKLUNG MICROELECTRONIC GMBH

MI.72xx - 32 bit Digital Pattern Generator with programmable logic levels

- Standard PCI format
- Programmable output levels from -2,0 V up to +10,0 V
- Levels individually programmable per 4 bit
- Up to 40 MS/s at 32 bit
- Possible use of memory saving 8 bit mode
- All Outputs can be separately disabled (Tristate)
- Hardware controlled differential output possible (8 bit and 16 bit)
- Up to 512 MByte on-board memory
- Output in FIFO mode
- Synchronization possible



Product range overview

Model	8 bit	16 bit	32 bit
MI.7210	10 MS/s	10 MS/s	
MI.7211	10 MS/s	10 MS/s	5 MS/s
MI.7220	40 MS/s	40 MS/s	
MI.7221	40 MS/s	40 MS/s	40 MS/s

Software/Drivers

A large number of drivers and examples are delivered with the board or are available as an option:

- Windows NT/2000 32 bit drivers
- Windows XP/Vista/7 32 and 64 bit drivers
- Linux 32bit and 64bit drivers
- SBench 6.x Base version for Windows and Linux
- Microsoft Visual C++ examples
- Borland Delphi examples
- Microsoft Visual Basic examples
- Microsoft Excel examples
- LabWindows/CVI examples
- LabVIEW - drivers (as option)
- DASYLab - drivers (as option)
- MATLAB - drivers (as option)
- Agilent VEE - drivers (as option)

General Information

The MI.72xx pattern generator series gives the user the possibility to generate digital data with a wide range of output levels. For every 4 bit the LOW and HIGH levels can be programmed from -2.0 V up to +10.0 V. Even at high speeds you are not limited concerning the maximum output swing. This enables the user to drive devices of nearly any logic family, like ECL, PECL, TTL, LVDS, LVTTTL, CMOS or LVCMOS. The potentially necessary differential signals are generated in hardware, so that only one data bit is used for each pair of differential signals. All outputs can be separately disabled allowing the easy connection with digital acquisition boards and the adaption to a wide range of test setups. The internal standard synchronization bus allows synchronisation of several MI.xxxx boards. Therefore the MI.72xx board can be used as an enlargement to any digital or analog board.

Hardware block diagram

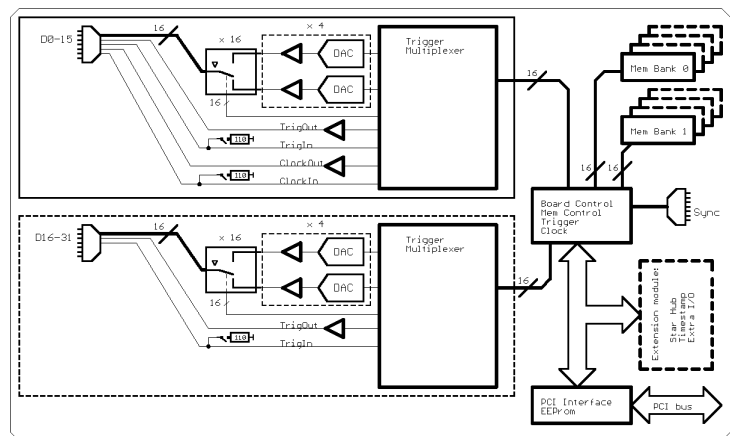

Software programmable parameters

sampling rate	1 kS/s to max sampling rate, external clock, ref clock
Output level	LOW/HIGH level p. nibble; -2,0 V up to +10,0 V in steps of 1mV
Clock mode	internal PLL, int.quartz, external, ext. divided, ext. reference clock
Clock impedance	110 Ohm / 50 kOhm
Trigger impedance	110 Ohm / 50 kOhm
Data Enable mask	programmable for every single bit
Trigger mode	External TTL, software
Memory depth	32 up to installed memory in steps of 32
Posttrigger	32 up to 256 M in steps of 32
Multiple Replay segment size	32 up to installed memory / 2 in steps of 32

Application examples

Semiconductor test	Production test	Burn-in test
Laboratory purposes	Pattern generator	Semiconductor development
Process control	ATE	

Possibilities and options

FIFO mode

The FIFO mode is designed for continuous data transfer between measurement board and PC memory (up to 100 MB /s) or hard disk (up to 50 MB/s). The control of the data stream is done automatically by the driver on interrupt request.

External trigger I/O

All boards could be triggered using an external TTL signal. It's possible to use positive or negative edge. An internally recognised trigger event could - activated by software - routed to the output connector to start external instruments.

External clock I/O

Using a dedicated connector a sampling clock can be fed in from an external system. It's also possible to output the internally used sampling clock to synchronise external equipment to this clock.

ECL Mode

When the ECL mode is activated, differential signals which are needed for e.g. ECL interfacing are generated in hardware on the odd data outputs. This results in the use of only one data bit for every pair of differential outputs and allows a very efficient use of memory.

Reference clock

The option to use a precise external reference clock (normally 10 MHz) is necessary to synchronize the board for high-quality measurements with external equipment (like a signal source). It's also possible to enhance the quality of the sampling clock in this way. The driver automatically generates the requested sampling clock from the fed in reference clock.

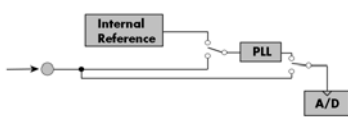

When the ECL mode is activated, differential signals which are needed for e.g. ECL interfacing are generated in hardware on the odd data

Cascading

The cascading option synchronises up to 4 Spectrum boards internally. It's the easiest way to build up a multi channel system. There is a phase delay between two boards of about 500 pico seconds when this synchronisation option is used.

Star-Hub

The star-hub is an additional module allowing the phase stable synchronisation of up to 16 boards. Independent of the number of boards there is no phase delay between all channels. The star hub distributes trigger and clock information between all boards. As a result all connected boards are running with the same clock and the same trigger.

Extra I/O

The Extra I/O module adds 24 additional digital I/O lines and 4 analog outputs on an extra connector. These additional lines are independent from the standard function and can be controlled asynchronously. There is also an internal version available with 16 digital I/Os and 4 analog outputs that can be used directly at the rear board connector.

Multiple Replay

The Multiple Replay option allows the fast repetition output on several trigger events without restarting the hardware. With this option very fast repetition rates can be achieved. The on-board memory is divided in several segments of same size. Each of them is generated if a trigger event occurs.

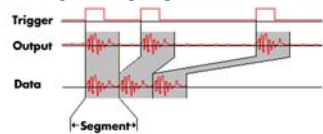

Gated Replay

The Gated Sampling option allows data replay controlled by an external gate signal. Data is only replayed if the

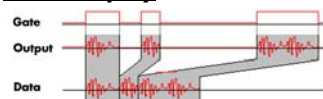

gate signal has a programmed level.

Singleshot output

When singleshot output is activated the data of the on-board memory is replayed exactly one time. As trigger source one can use the external TTL trigger or the software trigger.

Continuous output

When continuous output is activated the data of the on-board memory is replayed continuously until a stop command is executed. As trigger source one can use the external TTL trigger or the software trigger.

Technical Data

Internal samplerate	1 kS/s up to maximum (depending on model)			Dimension	312 mm x 107 mm
External samplerate	DC up to maximum (depending on model)			Width (MI.721x)	1 full size slot
Clock input impedance	110 Ohm / 50 kOhm 15 pF			Width (MI.722x)	1 full size slot and 1 half size slot
Trigger input impedance	110 Ohm / 50 kOhm 15 pF			Output connector	40 pole half pitch (Hirose FX2 series)
Output impedance	approximately 80 Ohm			Power connector (MI.722x only)	soldered Y - cable with Molex 8981 (5,25" disc drive connector)
Data signal level	programmable from -2.0 V up to +10.0 V with an accuracy of ± 10 mV				
Output swing	0.1 ... 12.0 V				
	per pin	per nibble	per card	Operating temperature	0°C to 50°C
Maximum output current	100 mA	200 mA	0.5 A (MI.721x only)	Storage temperature	-10°C to 70°C
Input signal level (trigger, clock)	3.3 V/ 5 V TTL compatible			Humidity	10% to 90%
Output signal level (trigger, clock)	5 V TTL				
	1 MHz	40 MHz			
Rise time ^a	2.00 ns	2.25 ns			
Fall time ^a	2.00 ns	2.25 ns			
Multi: Trigger to 1st sample delay	fixed				
Multi: Recovery time	< 20 samples (16 - 32 bit)				
	32 bit	16 bit	8 bit		
Trigger accuracy (samples)	1	1	2		

a. Tested with full output swing from -2.0 V to 10.0 V with no load

Trigger input: Standard TTL level	Low: -0.5 V > level < 0.8 V High: 2.0 V > level < 5.5 V Trigger pulse must be valid ≥ 2 clock periods.	Clock input: Standard TTL level	Low: -0.5 V > level < 0.8 V High: 2.0 V > level < 5.5 V Rising edge. Duty cycle: 50% \pm 5%
Trigger output	Standard TTL, capable of driving 50 Ohm. Low < 0.4 V (@ 20 mA, max 64 mA) High > 2.4 V (@ -20 mA, max -48 mA) One positive edge after the first internal trigger	Clock output	Standard TTL, capable of driving 50 Ohm Low < 0.4 V (@ 20 mA, max 64 mA) High > 2.4 V (@ -20 mA, max -48 mA)

Power consumption (maximum value)	Full speed			Power down mode		
	+5 V (PCI Bus)	+12 V (PCI Bus)	+12 V (Connector)	+5 V (PCI Bus)	+12 V (PCI Bus)	+12 V (Connector)
MI.7210 (16 bit output @ 10 MS/s) ^a	1.5 A (7.5 W)	0.35 A (4.2 W)	-	1.3 A (6.5 W)	0,07 A (0.9 W)	-
MI.7211 (32 bit output @ 5 MS/s) ^a	1.8 A (9.0 W)	0.40 A (4.8 W)	-	1.5 A (7.5 W)	0.15 A (1.8 W)	-
MI.7220 (16 bit output @ 40 MS/s) ^b	1.8 A (7.5 W)	0 A	1.8 A (21.6 W)	1.6 A (8.0 W)	0 A	0.2 A (2.4 W)
MI.7221 (32 bit output @ 40 MS/s) ^b	2.5 A (12.5 W)	0 A	3.6 A (43.2 W)	2.2 A (11.0 W)	0 A	0.5 A (4.8 W)

a. Tested with full output swing from -2.0 to 10.0 V with no load

b. Tested with full output swing from -2.0 V to 10.0 V with 50 mA output current per pin

Order information

Order No	Description	Order No	Description
MI7210	MI.7210 with 16 MByte (128 MBit) memory, cables and drivers	MI7xxx-32M	Option: 32 MByte memory instead of 16 MByte standard mem
MI7211	MI.7211 with 16 MByte (128 MBit) memory, cables and drivers	MI7xxx-64M	Option: 64 MByte memory instead of 16 MByte standard mem
MI7220	MI.7220 with 16 MByte (128 MBit) memory, cables and drivers	MI7xxx-128M	Option: 128 MByte memory instead of 16 MByte standard mem
MI7221	MI.7221 with 16 MByte (128 MBit) memory, cables and drivers	MI7xxx-256M	Option: 256 MByte memory instead of 16 MByte standard mem
		MI7xxx-512M	Option: 512 MByte memory instead of 16 MByte standard mem
MI7xxx-smod	Star Hub: Synchronisation of 2 - 16 boards, one option per system	MI7xxx-up	Additional handling cost for later memory upgrade
MIxxxx-xio	Extra I/O, internal connector: 16 DI/O, 4 Analog out	MI7xxx-mr	Option Multiple Replay: Memory segmentation
MIxxxx-xmf	Extra I/O, external connector: 24 DI/O, 4 Analog out, incl. cable	MI7xxx-gs	Option Gated Replay: Gate signal controls replay
		MI7xxx-cs	Synchronisation of 2 - 4 boards, one option per system
MI72xx-dl	DASYLab driver for MI.72xx series		
MI72xx-hp	VEE driver for MI.72xx series		
MI72xx-lv	LabVIEW driver for MI.72xx series	Cab-d40-idx-100	Additional 40 pole flat ribbon cable with IDC socket connector, ca. 1 m
MATLAB	MATLAB driver for all MI.xxxx, MC.xxxx and MX.xxxx series.	Cab-d40-d40-100	Additional 40 pole flat ribbon cable with Fx2 connector, ca. 1 m

Technical changes and printing errors possible