



SPECTRUM

SYSTEMENTWICKLUNG MICROELECTRONIC GMBH

MI.61xx - 4 channel 125 MS/s Arbitrary Waveform Generator

- Standard PCI format
- Fast 8 bit arbitrary waveform generator
- 2 or 4 channel versions
- Simultaneously sampling on all channels
- Output up to ± 3 V in 50 Ohm
- Amplifier option available for ± 10 V
- Offset and amplitude programmable
- 3 software selectable filters
- Up to 512 MSample memory
- FIFO mode
- Synchronization possible
- Software SPEasyGenerator included

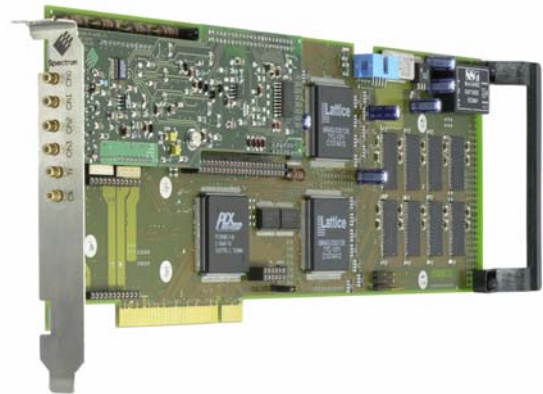

Product range overview

Model	1 channel	2 channels	4 channels
MI.6110	125 MS/s	125 MS/s	
MI.6111	125 MS/s	125 MS/s	125 MS/s

Software/Drivers

A large number of drivers and examples are delivered with the board or are available as an option:

- Windows NT/2000 32 bit drivers
- Windows XP/Vista/7 32 and 64 bit drivers
- Linux 32bit and 64bit drivers
- SBench 6.x Base version for Windows and Linux
- Microsoft Visual C++ examples
- Borland Delphi examples
- Microsoft Visual Basic examples
- Microsoft Excel examples
- LabWindows/CVI examples
- LabVIEW - drivers (as option)
- DASYLab - drivers (as option)
- MATLAB - drivers (as option)
- Agilent VEE - drivers (as option)

General Information

The MI.61xx series offers 2 different versions of arbitrary waveform generators for the PCI bus. With these boards it is possible to generate free definable waveforms on several channels synchronously. There are two or four channels on one board with a synchronous sampling rate of 125 MS/s. The internal standard Sync-bus allows the setup of synchronous multi channel systems with higher channel numbers. It is also possible to combine the arbitrary waveform generator with other boards of the MI product family like analogue or digital acquisition boards.

With the up to 512 MSample large on-board memory long waveforms can be generated even with high sampling rates. The memory can also be used as a FIFO buffer to make continuous data transfer from PC memory or hard disk.

Hardware block diagram

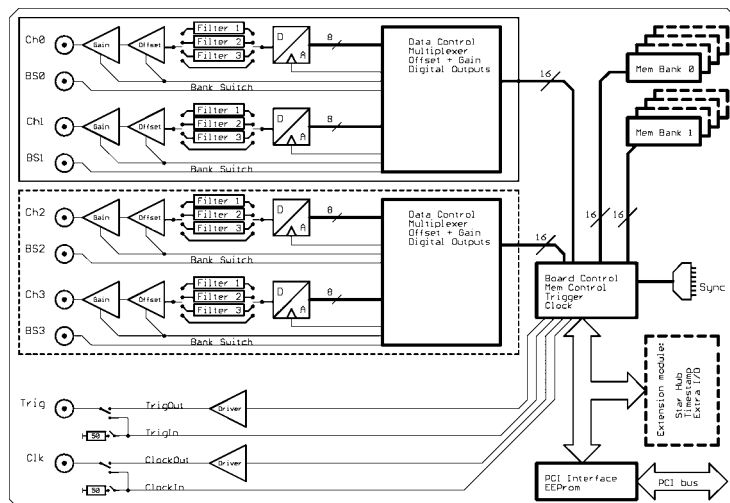

Software programmable parameters

sampling rate	1 kS/s to max sampling rate, external clock, ref clock
Output amplitude	± 100 mV up to ± 3 V in 1 mV steps (Amp option: ± 333 mV up to ± 10 V)
Output offset	± 3 V selectable in 1 mV steps (Amp option: ± 10 V in 3 mV steps)
Filters	no filter or one of 3 different filters as defined in technical data section
Mode	Singleshot, Continuous, Standard, Bank Switching
Clock mode	internal PLL, int.quartz, external, ext. divided, ext. reference clock
Clock impedance	50 Ohm / 1 MOhm
Trigger impedance	50 Ohm / 1 MOhm
Trigger mode	External, Software
Memory depth	32 up to installed memory in steps of 32
Posttrigger	32 up to 128 M in steps of 32
Multiple Replay segmentsize	32 up to installed memory / 2 in steps of 32

Possibilities and options

FIFO mode

The FIFO mode is designed for continuous data transfer between measurement board and PC memory (up to 100 MB /s) or hard disk (up to 50 MB/s). The control of the data stream is done automatically by the driver on interrupt request.

External trigger I/O

All boards can be triggered using an external TTL signal. It's possible to use positive or negative edge also in combination with a programmable pulse width. An internally recognised trigger event can - when activated by software - be routed to the trigger connector to start external instruments.

External clock I/O

Using a dedicated connector a sampling clock can be fed in from an external system. It's also possible to output the internally used sampling clock to synchronise external equipment to this clock.

Reference clock

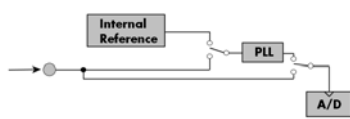

The option to use a precise external reference clock (normally 10 MHz) is necessary to synchronize the board for high-quality mea-

surements with external equipment (like a signal source). It's also possible to enhance the quality of the sampling clock in this way. The driver automatically generates the requested sampling clock from the fed in reference clock.

Cascading

The cascading option synchronises up to 4 Spectrum boards internally. It's the easiest way to build up a multi channel system. There is a phase delay between two boards of about 500 pico seconds when this synchronisation option is used.

Star-Hub

The star-hub is an additional module allowing the phase stable synchronisation of up to 16 boards. Independent of the number of boards there is no phase delay between all channels. The star hub distributes trigger and clock information between all boards. As a result all connected boards are running with the same clock and the same trigger.

Extra I/O

The Extra I/O module adds 24 additional digital I/O lines and 4 analog outputs on an extra connector. These additional lines are independent from the standard function and can be controlled asynchronously. There is also an internal version available with 16 digital I/Os and 4 analog outputs that can be used directly at the rear board connector.

Multiple Replay

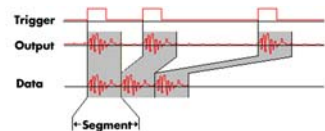

The Multiple Replay option allows the fast repetition output on several trigger events without restarting the hardware. With this option very fast repetition rates can be achieved.

The on-board memory is divided in several segments of same size. Each of them is generated if a trigger event occurs.

Gated Replay

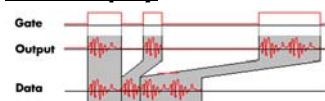

The Gated Sampling option allows data replay controlled by an external gate signal. Data is only replayed if the gate signal has a program-

med level.

Singleshot output

When singleshot output is activated the data of the on-board memory is replayed exactly one time. As trigger source one can use the external TTL trigger or the software trigger.

Continuous output

When continuous output is activated the data of the on-board memory is replayed continuously until a stop command is executed. As trigger source one can use the external TTL trigger or the software trigger.

±10 V Amplifier



The amplifier board allows the output of ± 10 V on up to four channels without software modification. The standard outputs of the card are amplified by factor 3.33. The amplifier which has 30 MHz bandwidth has an output impedance of 50 Ohm. This allows ± 10 V with high impedance termination or ± 5 V with 50 ohm termination.

Technical Data

Resolution	8 Bit	Dimension	312 mm x 107 mm
Integral linearity (DAC)	± 1.5 LSB typ.	Width (Standard)	1 full size slot
Differential linearity (DAC)	± 1.0 LSB typ.	Width (with star hub option)	2 full size slots
Output resistance	< 1 Ohm	Width Amplifier option	1 half size slot
Max output swing in 50 Ohm	± 3 V (offset + amplitude)	Analogue connector	3 mm SMB male
Max slew rate (no filter)	> 0.9 V/ns	Warm up time	10 minutes
Multi: Trigger to 1st sample delay	fixed	Operating temperature	0°C - 50°C
Multi: Recovery time	< 20 samples	Storage temperature	-10°C - 70°C
Ext. clock: delay to internal clock	42 ns ± 2 ns	Humidity	10% to 90%
Output to trigger out delay 1 channel	<10 MS/s: -10 sampl., >10 MS/s: -42 sampl.	Offset stepsize	< 2 mV
Output to trigger out delay 2 channels	<5 MS/s: -5 sampl., > 5 MS/s: -21 sampl.	Amplitude stepsize	< 1 mV
Crosstalk @ 1 MHz signal ±3 V	< -80 dB	Output accuracy	< 1%
Min internal clock	1 kS/s	Power consumption 5 V @ full speed	max 3.7 A (18.5 Watt)
Min external clock	DC	Power consumption 5 V @ power down	max 2.3 A (11.5 Watt)
Trigger input: Standard TTL level	Low: -0.5 V > level < 0.8 V High: 2.0 V > level < 5.5 V Trigger pulse must be valid ≥ 2 clock periods.	Clock input: Standard TTL level	Low: -0.5 V > level < 0.8 V High: 2.0 V > level < 5.5 V Rising edge. Duty cycle: 50% ± 5%
Trigger output	Standard TTL, capable of driving 50 Ohm. Low < 0.4 V (@ 20 mA, max 64 mA) High > 2.4 V (@ -20 mA, max -48 mA) One positive edge after the first internal trigger	Clock output	Standard TTL, capable of driving 50 Ohm Low < 0.4 V (@ 20 mA, max 64 mA) High > 2.4 V (@ -20 mA, max -48 mA)

Clock and Filter

	MI.6110	MI.6111
max internal clock	125 MS/s	125 MS/s
max external clock	125 MS/s	125 MS/s
-3 dB bandwidth no filter	> 60 MHz	> 60 MHz
Filter 3: Characteristics	5th order Butterworth	
Filter 3: -3 dB bandwidth	25 MHz	25 MHz
Filter 2: Characteristics	4th order Butterworth	
Filter 2: -3 dB bandwidth	5 MHz	5 MHz
Filter 1: Characteristics	4th order Butterworth	
Filter 1: -3 dB bandwidth	500 kHz	500 kHz

Dynamic Parameters

	MI.6110	MI.6110
	MI.6111	MI.6111
Test - Samplerate	125 MS/s	125 MS/s
Output Frequency	400 kHz	4 MHz
Output Level	±2 V	±2 V
Used Filter	500 kHz	5 MHz
SNR (typ)	> 60.9 dB	> 55.2 dB
THD (typ)	< -69.1 dB	< -58.08 dB
SFDR (typ), excl harm.	> 71.9 dB	> 65.6 dB

Dynamic parameters are measured at the given output level and 50 Ohm termination with a high resolution data acquisition card and are calculated from the spectrum. The sample rate that is selected is the maximum possible one. All available channels are activated for the tests. SNR and SFDR figures may differ depending on the quality of the used PC. SNR = Signal to Noise Ratio, THD = Total Harmonic Distortion, SFDR = Spurious Free Dynamic Range

Order information

Order No	Description	Order No	Description
MI6110	MI.6111 with 16 MSample memory and drivers/SBench 5.x	MI61xx-32M	Option: 32 MSample mem instead of 16 MSample standard mem
MI6111	MI.6111 with 16 MSample memory and drivers/SBench 5.x	MI61xx-64M	Option: 64 MSample mem instead of 16 MSample standard mem
MI6xxx-mr	Option Multiple Replay: Memory segmentation	MI61xx-128M	Option: 128 MSample mem instead of 16 MSample standard mem
MI6xxx-gs	Option Gated Sampling: Gate signal controls replay	MI61xx-256M	Option: 256 MSample mem instead of 16 MSample standard mem
MI6xxx-cs	Synchronisation of 2 - 4 boards, one option per system	MI61xx-512M	Option: 512 MSample mem instead of 16 MSample standard mem
MI6xxx-smod	Star Hub: Synchronisation of 2 - 16 boards, one option per system	MI61xx-up	Additional handling costs for later memory upgrade
MIxxxx-xio	Extra I/O, internal connector: 16 DI/O, 4 Analog out	MI6xxx-1Amp	±10 V Amplifier board with 1 channel
MIxxxx-xmf	Extra I/O, external connector: 24 DI/O, 4 Analog out, incl. cable	MI6xxx-2Amp	±10 V Amplifier board with 2 channels
Cab-3f-9m-80	Adapter cable: SMB female to BNC male 80 cm	MI6xxx-4Amp	±10 V Amplifier board with 4 channels
Cab-3f-9m-200	Adapter cable: SMB female to BNC male 200 cm	MI61xx-dl	DASYLab driver for MI.61xx series
Cab-3f-9f-80	Adapter cable: SMB female to BNC female 80 cm	MI61xx-hp	VEE driver for MI.61xx series
Cab-3f-9f-200	Adapter cable: SMB female to BNC female 200 cm	MI61xx-lv	LabVIEW driver for MI.61xx series
		MATLAB	MATLAB driver for all MI.xxxx, MC.xxxx and MX.xxxx series.

Technical changes and printing errors possible