

► Product Note

## Proper Use of Digitizer Front-End Signal Conditioning

### Introduction

Modular digitizers and similar measuring instruments such as the Spectrum Instrumentation model M4i series shown in Figure 1, need to match a wide variety of signal characteristics to the fixed input range of the internal analog to digital converter (ADC).

Digitizer front ends must also minimize loading of the device being tested and provide appropriate coupling. Additionally, filtering may be needed to reduce the impact of broadband noise. All of these features are provided by the instruments 'front end' which includes all the circuitry between the input and the ADC. Digitizer users need to understand the trade-offs required in order to use these instruments effectively.

Figure 2 shows a block diagram of the Spectrum M4i series modular digitizer used in this example. Each input channel has its own front end (shaded in green) that can be setup independently of the others. The front end provides appropriate input coupling and termination along with range selection and bandwidth limit filtering.

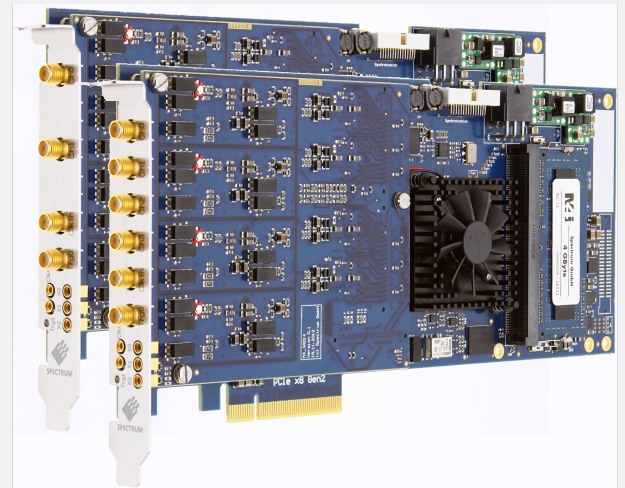

Figure 1: Spectrum M4i.44xx high speed digitizer including both the 2 and 4 channel versions with resolutions of 14 or 16 bits.

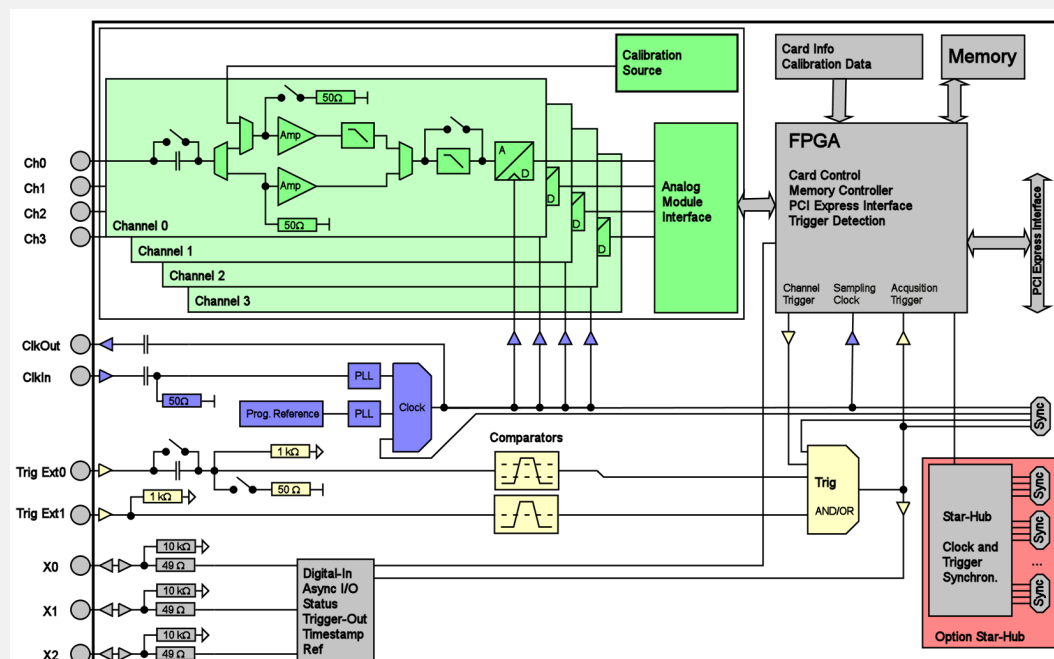

Figure 2: The block diagram of a Spectrum M4i.44xx PCI Express 14/16bit modular digitizer. The front ends for each channel are shown in green. The front end provides appropriate input coupling and termination along with range selection and bandwidth limit filtering.

## ▶ Product Note

### Front End Features

Maximizing the versatility of a modular digitizer requires that the front end circuits have the following capabilities:

1. A selection of input termination to offer matching impedances or minimized loading with a high impedance input.
2. A choice of coupling modes to offer either AC or DC coupling as needed.
3. Filtering to minimize noise and reduce harmonic components if present.
4. Multiple input ranges offering the ability to capture a wide variation in input signal levels and at the same time minimizing noise and distortion to maintain signal integrity.
5. Internal calibration to maximize accuracy.

### Input Termination

A measuring instrument should terminate the source properly. For most radio frequency (RF) measurements this is generally a  $50\ \Omega$  termination. A matching termination minimizes signal losses due to reflections. The figures of merit for the  $50\ \Omega$  matching are return loss or voltage standing wave ratio (VSWR). Either of these figures of merit indicate the quality of the impedance match.

If the source device has a high output impedance then it is more properly matched with a 1 Mega-ohm ( $M\Omega$ ) high impedance termination which minimizes circuit loading. The  $1\ M\Omega$  termination also allows the use of high impedance oscilloscope probes which further increase the load impedance.

Impedance matching to other standard terminations, like  $600\ \Omega$  for audio, can be accomplished by using a  $1\ M\Omega$  termination combined with an external  $600\ \Omega$  termination.

Since there is an engineering tradeoff in designing with selectable input impedance between convenience and signal integrity some modular digitizer suppliers only offer  $50\ \Omega$  termination. If you need a high impedance termination or both high impedance and  $50\ \Omega$  you should verify that the manufacturer does offer it. The Spectrum M4i series has been designed to offer users a choice of input terminations while maintaining the highest level of signal integrity.

### Input Coupling

Input coupling in a measurement instrument offers the ability to AC or DC couple the measuring instrument to the source. DC coupling shows the entire signal including any DC offset (non-zero mean signals). AC coupling eliminates any steady state mean value (DC). AC coupling is useful for measurements such as ripple measurements on the output of a DC power supply. Without the AC coupling the DC output would require a large signal attenuation which would make the ripple harder to measure accurately. With AC coupling a higher input sensitivity can be used resulting in a better measurement of the ripple component.

The key specification for AC coupling is its low frequency cutoff (lower -3 dB point) of the AC coupled frequency response. This determines how much a low frequency signal will be attenuated by the AC coupling. It also is related to the recovery time, which is the time it takes for the input level to settle after the DC level applied to the instrument changes.

## ▶ Product Note

Generally, the lower the cutoff frequency the larger the coupling capacitor and the longer the settling time.

Some modular digitizers offer only AC or DC coupling and not a selection of either. Again, this is an engineering tradeoff to reduce complexity because a digitizer with fixed coupling doesn't have to deal with components like relays or switches. Again, your application will determine if a fixed or selectable coupling is acceptable. Selectable coupling offers more flexibility in case your measurement needs change.

## Input Voltage Ranges

The digitizers ADC generally has a fixed input range. The simplest interface is to have a single input with a fixed input range matching the ADC's. While simple, this is not very practical in a measuring instrument unless the single range is exactly the one you want to use. To bring the input signal swing into the range of the ADC requires either an attenuator or an amplifier.

An attenuator is a simple voltage divider, generally resistive, which reduces the amplitude of the input signal. When designed with quality components it generally does not degrade signal integrity significantly. One issue that appears when attenuators are in the signal path is that the instruments internal noise amplitude scales (relative to the input of the attenuator) with the front end attenuation. So if you have a digitizer with a 58  $\mu\text{V}$  rms noise level and you add a 10:1 attenuator, then the noise level, referenced to the input, has a level of 580  $\mu\text{V}$ . The noise level is still the same relative percentage of the attenuated full scale range.

Amplifiers are another story. Even properly designed they generally introduce noise into the signal path. This is somewhat compensated for by the fact that the digitizers internal noise decreases by the gain of the amplifier when referenced to the input. Amplifiers can also introduce distortion products which further degrades signal integrity. Another limitation of amplifiers is that they have a fixed gain-bandwidth product. If you attempt to increase their gain then the bandwidth must fall proportionally. You can see this on high sensitivity ranges where the bandwidth is reduced.

Input voltage range selection is a critical area in modular digitizer design because it can have a great effect on signal integrity. At the same time it offers greater flexibility to the user in matching the available signal amplitudes to the digitizer input range. Suppliers offer a variety of approaches to handling this tradeoff. They vary from offering a single fixed input range, which shifts design work from the digitizer manufacturer to the end user who needs to care for correct amplification by himself, to offering multiple input paths. The multiple input paths combine a "Buffered" path offering the greatest versatility with regard to input ranges and termination, with a "50  $\Omega$ " high Frequency (HF) path which provides the highest bandwidth and the best signal integrity with a fewer number of input ranges and a fixed 50  $\Omega$  termination.

The block diagram in Figure 3 shows the architecture of a Spectrum Instrumentation M4i.44xx modular digitizer which includes a dual input path.

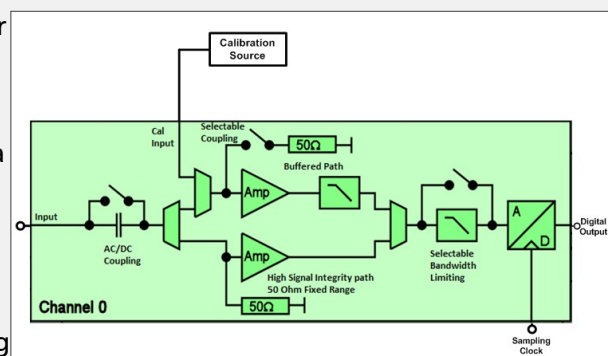

Figure 3: The block diagram of a Spectrum Instrumentation M4i.44xx Digitizer showing all the elements of a full featured front end including dual input paths, coupling, termination impedance, filtering, and internal calibration.

► **Product Note**

The HF path is optimized to deliver the greatest bandwidth with the best signal fidelity. The buffered path provides the greatest versatility by offering more and broader choices of input voltage ranges. Users can select the input path which best matches their measurement requirements.

	High Frequency Path	Buffered Path
Analog Input Impedance	50 Ω	1 MΩ    25 pF or 50 Ω
Input Voltage Ranges	±500 mV, ±1 V, ±2.5 V, ±5 V	±200 mV, ±500 mV, ±1 V, ±2 V, ±5 V, ±10 V
Input Coupling	AC/DC	AC/DC
Maximum Bandwidth	250 MHz	125 MHz
RMS noise level (no signal) at ±500 mV	< 58 μV	< 70 μV

Table 1 contains a comparison of the characteristics of each path for the 14 bit, 500 MS/s version (Model M4i.445x).

**Table 1: A comparison of the HF and Buffered path characteristics in a 14 bit, 500 MS/s modular digitizer**

Figure 4 offers a comparison of the response of the HF and Buffered paths to a 256 step ramp on the digitizers 500 mV range. In this figure we are looking at a single step in each path (note that adjacent steps have been selected for each path so they do not overlap).

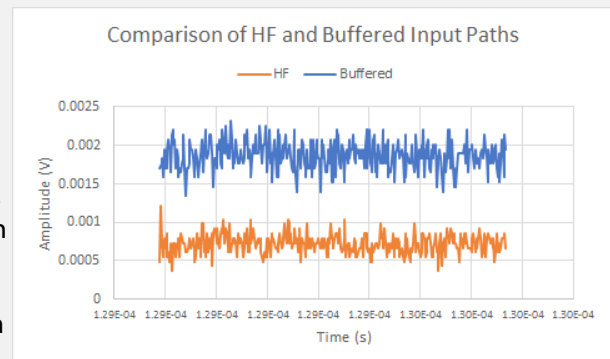
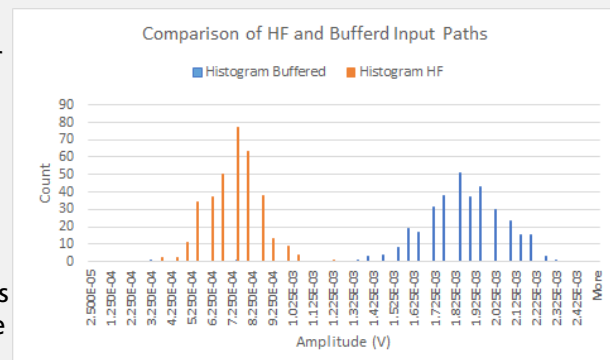

**Figure 4: The differences in the response of the HF and Buffered. Note the higher peak to peak noise level in the buffered path despite the bandwidth of the buffered path being half that of the HF path.**

Note that the peak to peak noise in the buffered path is higher than in the HF path. The HF path design has been optimized to minimize noise and despite having twice the bandwidth of the buffered path it still shows much less noise. The price that is paid for this performance is a reduction in the number in input ranges available and the necessity to use the 50 Ω termination.

Note that if you select a modular digitizer that only offers the equivalent of the buffered path you are 'stuck' with the higher noise level.

Looking at the histograms of these waveform, shown in Figure 5, we can see that the spread about the mean for the HF path is smaller than that for the Buffered path. This means that there is less variation or noise in the HF path.



**Figure 5: The histogram of data values for both the HF and Buffered signal paths showing the narrower distribution of the HF path indicating a lower noise level.**

The measure of this phenomena is the standard deviation. In this example the standard deviation of the HF path is 0.125 mV while that of the Buffered path is 0.183 mV. This provides a quantization of the differences in noise level between the two signal paths for the same input signal.

It should be noted that both responses also contain noise components from the signal source as well as the digitizer.

## Product Note

The advantage of the higher signal integrity of the HF can also be seen in the frequency spectrum of sine wave acquired by the digitizer using both input signal paths. This is shown in Figure 6. Here the fast Fourier transform (FFT) of the acquired signals through each input path is shown. Cursors mark the spectrum peak and the peak of the highest spurious. The HF path has a spurious free dynamic range of 80.9 dB compared with 60.7 dB for the Buffered path. Note also that the noise baseline is lower in the HF signal path case.

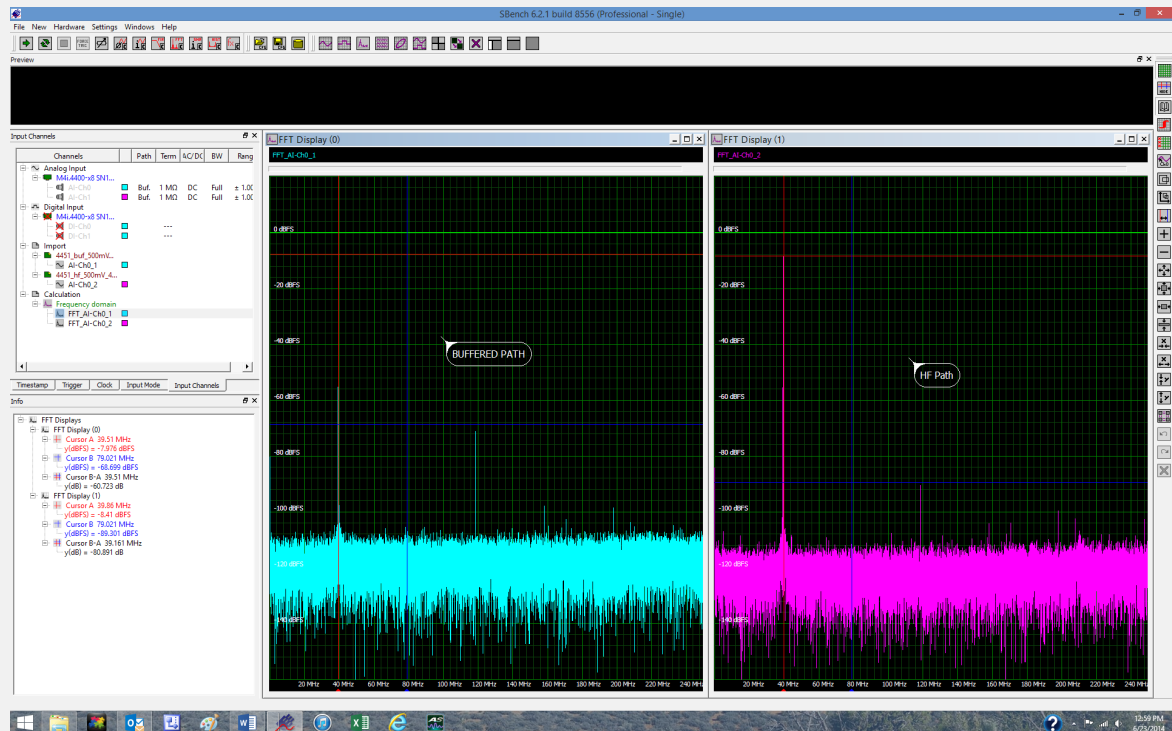

**Figure 6: Comparing the frequency Spectrum of the Buffered (left side) and HF (right side) paths. Note that the HF path has a spurious free dynamic range of 80.9 dB compared with 60.7 dB for the Buffered path**

## Some Observations on Improving Signal Integrity

No matter which signal path you choose there are some general rules to help get the best signal integrity. The first is to use as much of the input range as possible. If the signal has a stable amplitude then select an input range that uses at least 90% of that range. Do not overdrive the ADC. If you exceed the full scale range the result will be distortion or clipping which will produce unwanted harmonics and decrease signal integrity.

Bandwidth limiting filters, if available in your digitizer, can help reduce noise. In the digitizers used in this article there is an analog 20 MHz low pass filter in the front end that can be switched in to limit the digitizer bandwidth. If the input signal has no content above 20 MHz then using the filter will improve the signal to noise ratio of your acquisition by reducing noise above 20 MHz.

## Built-in Calibration

All of the modular digitizer channels from Spectrum are factory calibrated before being shipped. Since the modular digitizer is incorporated into the PC environment where there



## ▶ Product Note

may be variations like PC power supply voltages and temperature the software driver for this digitizer provides routines for an automatic on-board offset and gain (Buffered signal path only) calibration of all input ranges of the Buffered signal path. Each digitizer card contains a high precision built-in calibration reference. This is a great feature to help keep the digitizer calibrated despite change in the environment and aging. Good practice is to ensure you perform a calibration once the digitizer is operational and has had sufficient time to reach a stable operating temperature. This is typically reached after 10 to 15 minutes.

## Conclusion

The front end of the modular digitizer needs to provide all the features necessary to insure accurate, repeatable measurements. Multiple input ranges, AC/DC coupling, filtering, and built-in calibration all help to insure maximum signal integrity and accuracy. A well designed front end will allow the user to condition the input signal appropriately, ensuring it covers as much of the ADC range as possible without overdriving it. Only then can the digitizer achieve the best measurement accuracy and precision.

### Authors:

*Arthur Pini Independent Consultant*

*Greg Tate Asian Business Manager, Spectrum GmbH*

*Oliver Rovini Technical Manager, Spectrum GmbH*